

Seed Hawk

Precision seeding technology





Welcome to Väderstad

Together with farmers all over the world, we have spent the last three generations creating machines that make any farmland find its full potential. The high quality Väderstad planters, seed drills and tillage equipment give farmers a head start by covering more ground in shorter time without losing perfection.

Together we make you an even more successful farmer.



Precision seeding, powerful crops

Seeding marks the dawn of a new crop year and its importance to a profitable bottom line cannot be understated. Seed Hawk seeders are known for their ability to maximize the potential of the plant with innovations in seed-to-fertilizer placement, accurate metering and superior functionality.





Unparalleled accuracy

The heart of the Seed Hawk seeder is the individually mounted opener assemblies. Each independent dual-knife opener and packer assembly delivers unparalleled accuracy in all soil conditions. The result is an excellent quality crop with maximum yield potential.



A perfect micro climate

The Seed Hawk seeder establishes the crop in shallow strips, while leaving the rest of the field untouched. Standing stubble rows beside the young plants offer protection from wind and soil erosion. The dual-knife system helps warm the soil while preserving moisture. This ensures quick and strong plant development with good vigor to withstand pests and disease.

Right rate, right time

The Fenix III metering system found on Seed Hawk iCon systems allows for precise delivery of seed and fertilizer. Heavy-duty electric motors, in conjunction with application-specific rollers, produce the desired amount of product for each section of the toolbar.



Ease of use

The iPad based iCon control system simplifies calibration and operation of the machine. Automated sectional control and wireless blockage systems have the driver in focus while never compromising on agronomy.

Top quality

The Seed Hawk seeder has a heavy-duty design with high quality components and few moving parts. The fertilizer and seed knife working in the soil is protected by carbide tips. You benefit from an excellent performance and extremely long working life in the field.

Depth maintenance in all situations

A successful crop requires each plant to be seeded at the same depth regardless of soil conditions and terrain. Seed Hawk's multi-plex frames and independent opener design allows each plant to begin its growth cycle evenly across the entire toolbar.





Accurate seed depth, every time

The working depth of the Seed Hawk opener is maintained by the packer wheel following the ground surface directly behind the fertilizer and seed knives. The hydraulic cylinder applies downforce on the wheel, which results in up to 330 lb (150 kg) pressure. Adjustable packing pressure ensures great results in any soil condition.

The Seed Hawk opener is always able to maintain its selected working depth, resulting in an evenly-maturing crop every time.

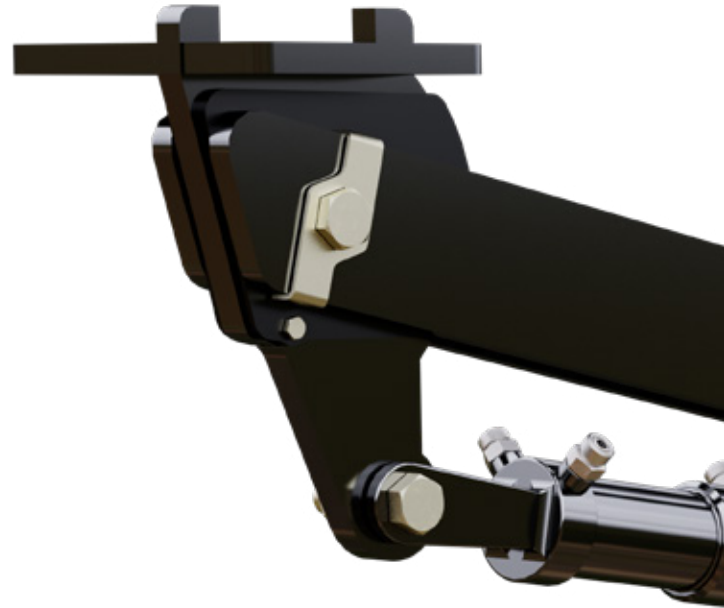

Extreme adaptability

The opener assemblies follow the ground independently by pivoting at the frame. With a contour following range of 8 inches, each independent opener delivers consistent seed depth, regardless of the terrain.

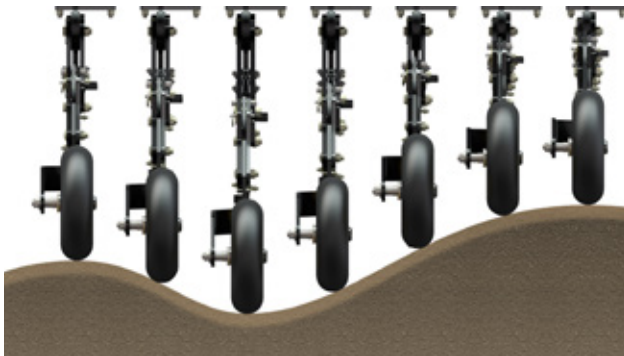

The Seed Hawk opener performs seedbed preparation, fertilizer and seed placement as well as reconsolidation in one pass. A simple pin adjustment allows for quick and precise depth setting.

Row by row control

By controlling each row individually, each seed is granted the same great conditions for growth. A consistent contour following ability is crucial in no-till operations where variable field conditions are present. The Seed Hawk opener excels in this area.



Knife design promotes depth keeping

The fertilizer knife is angled forward, improving entry in tough conditions. This also helps pull the opener down, maintaining accurate depth control with a low hydraulic requirement.



Large packer wheel

The press wheel is wider than the operating area of the two knives. This allows it to ride on undisturbed soil and maintain depth in a variety of conditions.



Unlock the potential of the seed

A seed's greatest potential is at the time it is placed in the ground. For over a quarter century, Seed Hawk's innovative opener design has provided the precision seed-to-fertilizer placement required for the plant to produce a quality, high-yielding crop in all soil types and conditions.





Two knives, two working zones

The perfect separation of fertilizer and seed is obtained through the dual-knife system where the second knife covers the fertilizer with soil before dropping the seed. This creates a barrier between the seed and fertilizer, preventing fertilizer burn while allowing the seed early access to nutrients.



The hygienic seed slot

The Seed Hawk knives ensures that no hair pinning or mixing can occur. Thereby the seed is granted a clean seed slot free of residues.

Lifting up moisture

The fertilizer knife, which runs deeper than the seed knife, brings up moist soil from below. Therefore, the seed is afforded greater moisture access at this early, critical growth stage.

Beneficial seed furrow

The flat faced design of the knives creates fine tilth, securing seed-to-soil contact. Additionally, the knives create an open sidewall and furrow bottom free of compaction or smearing which promote air and moisture exchange as well as root development.

Reconsolidates with precision

The Seed Hawk press wheel puts more pressure on the fertilizer row to seal in moisture and aid dissolving. By providing a slight sideways pressure over the seed, the press wheel prevents capping. The result is a perfect contact between seed and soil.

Superior conditions for growth

Germination is the most critical stage of the growth process. It is crucial for the plant to be able to access nutrients quickly and safely in order to get the jump out of the ground it requires.

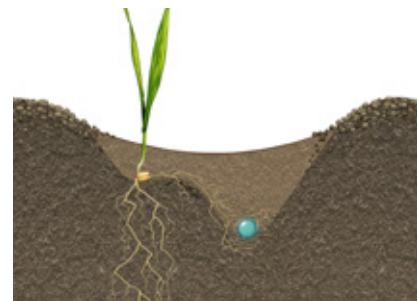
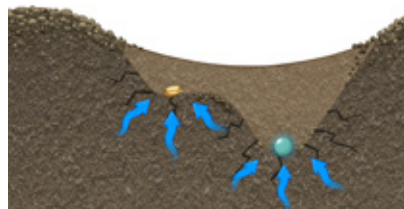
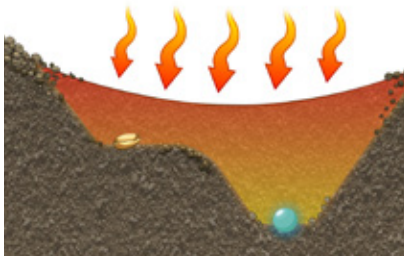
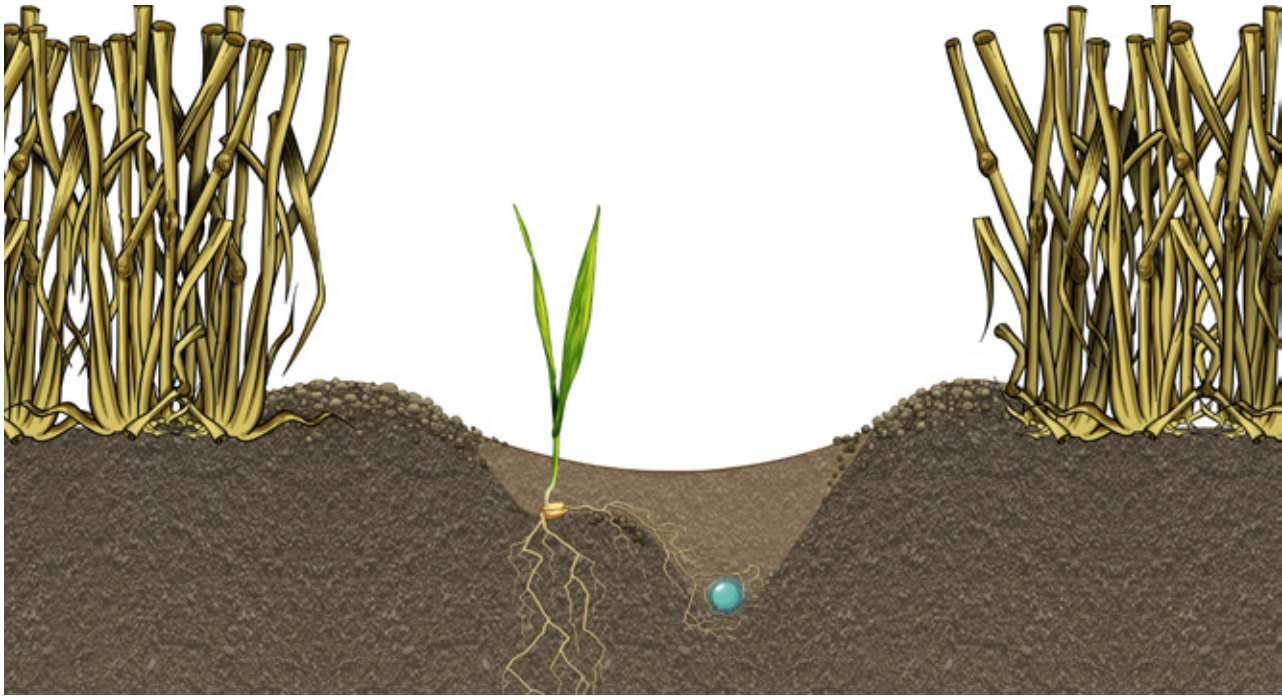

Quick warm-up

To trigger the seed growth, the right temperature must be reached in the seed furrow. The furrow created by the opener acts in the same way as strip tillage, where the strip warms up faster than the surrounding soil. This speeds up the germination process.

Promotes growth

Both the fertilizer and the seed are placed on uncultivated soil, providing great access to capillarity water. This secures a fast swelling of the seed. As a complement, the stubble and crop residues between the rows, retains humidity in the ground.

Root development

The seed is placed on firm, moist soil so the radicle has immediate and continued access to moisture. The fine tilth beside the seed allows other roots to develop and rapidly branch out towards the fertilizer band. This aids quick emergence and vigorous growth of the developing plant.

Knife options

Single Side Band Knife

The Single Side Band Knife is the leader in precision seed and fertilizer placement. It cuts shallow, separate trenches for seed and fertilizer, placing seed on undisturbed soil and fertilizer in the best position for

superior uptake, while also protecting seedlings. The result is quicker germination and more even emergence, in all soil conditions.

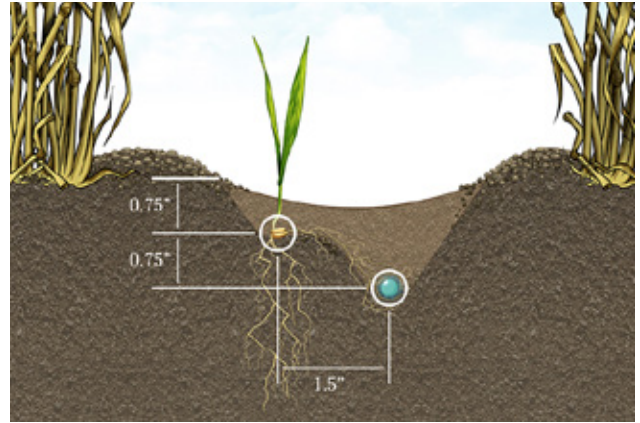

Seed Hawk's Single Side Band Knife overcomes the limitations of all-in-one side band openers.

Inline Side Band Knife

The all-new Inline Side Band knives achieve side band placement with an inline knife design. The seed knife cuts a separate shallow trench where an angled seed tube is used to place the seed 2" away from and 0.75" above the fertilizer. The new inline design allows for better soil flow

and performance in residues resulting in a smoother field finish. The new inline system also allows the grower to easily switch from Side Band to Twin Row placement if desired.

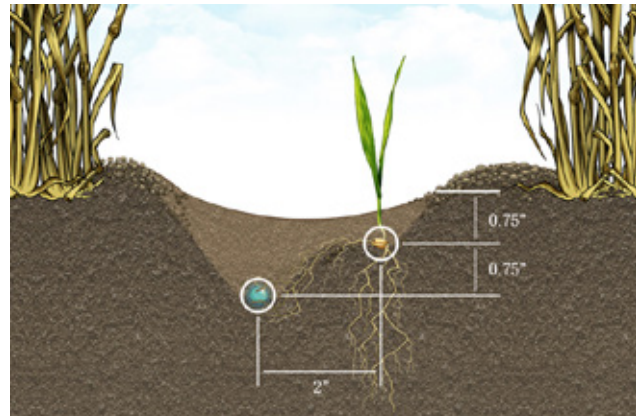

Twin Wing Knife

If narrower spacing is desired, growers have the option to equip their 12 inch toolbars with twin wing openers to create 9 inch of spacing between seeded rows. The design ensures that two distinct rows emerge, while providing proper separation of seed and fertilizer.



Growers can equip a machine with 12" row spacing to create 9" spacing between seed rows. The wider shank distribution improves residue clearance, and tighter row spacing increases seed bed use, making the emerging crop a better competitor for weeds.

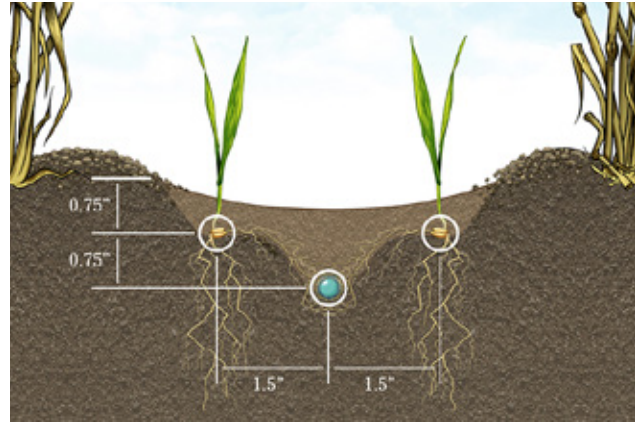

Independent research shows the Twin Wing precisely places seed and fertilizer separately to ensure fast, uniform germination. *WADO Research*

		Performance Overview								
	Available on	Soil Disturbance	Trash Flow	Propensity for Plugging	Moist Conditions	Dry Conditions	Heavy Soils	Medium Soils	Light Soils	Power Requirements
Single Side Band	10" or 12" Row Spacing	Average	Average	Minimal	Excellent	Excellent	Excellent	Excellent	Excellent	5 hp per opener
Inline Side Band	10" or 12" Row Spacing	Minimal	Improved	Average*	Marginal	Excellent	Average	Excellent	Excellent	5 hp per opener
Twin Wing	12" Row Spacing, creating 9" rows	Increased	Improved	Average**	Marginal	Excellent	Marginal	Excellent	Excellent	6 hp per opener

*Propensity for plugging largely depends on soil types and moisture. With heavier soils and high moisture, the propensity factor will be increased.

** Propensity for plugging largely depends on soil types and moisture. With heavier soils and high moisture, the propensity factor will be increased. Additionally, pulses and other large seeds may see difficulty at the flat plate of the knife during high application rates.



Quality metering, quality performance

With planting season often being a time-critical operation, Seed Hawk growers rely on the patented Fenix III metering system for unmatched product delivery. Its precise, reliable and simple operation allows for a wide range of flexibility to suit all types of seeding applications.



VADERSTAD

Fenix III

Fenix III



Precision and performance

Farming's most advanced seed metering technology is engineered for exceptionally precise seeding, reliable performance and easy maintenance, year after year.

Constant precision

Fenix III guarantees a consistent flow of all products. Its design ensures the meter can handle difficult products such as inoculants, micronutrients, high fertilizer rates and large seed sizes.

A high torque motor makes it possible to meter a wide range of seed and products at a variety of rates.

Even product flow

The Fenix III OffSet rollers do not fill and empty across the entire width at the same time. Instead, they alternate feeding from one side of the roller to the other. Together with an angled design of the meter outlet, this ensures a smooth, constant product flow with minimized pulsing.

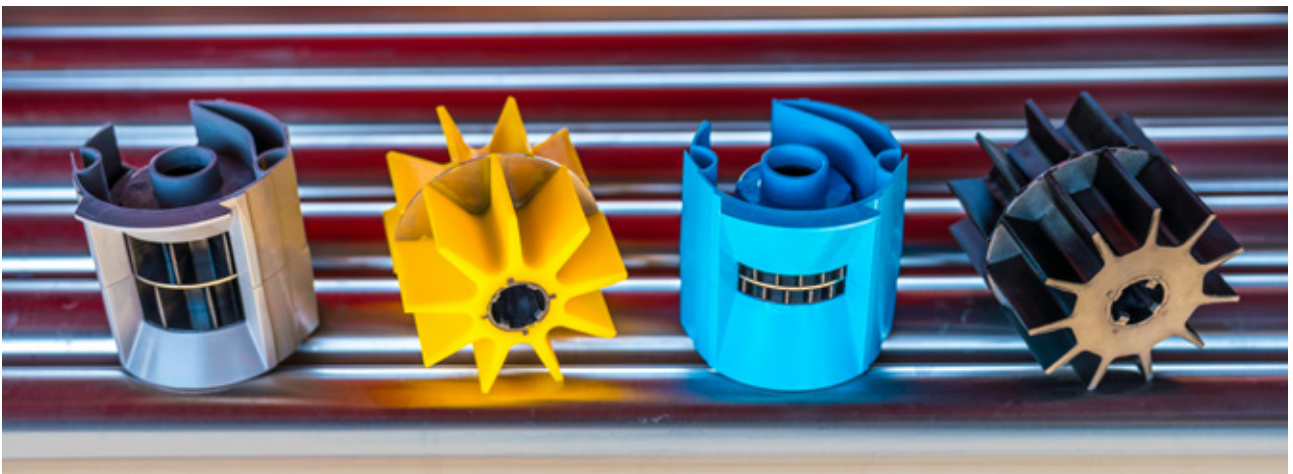

Reliable metering

Fenix III has heavy-duty components to ensure a robust, durable meter able to withstand a wide variety of abrasive products.

Having soft roller flutes prevents jamming and motor failure, thereby ensuring a reliable rate of delivery.

Simple operation

The design of the Fenix III meter, where the roller is placed directly on the electric motor axle, makes it an easy-to-use system. With only a few moving parts and no grease zerks, maintenance is simple.

Changing rollers between crops is performed in a matter of seconds.

Full control by 10 foot sections

Crop inputs are a substantial investment on every farm. Maximize the return on your investment by using Seed Hawk's precision farming technology to focus the product on where it needs to go. In the field, the Fenix III meters on the Air Cart seamlessly works together with the Toolbar to allow full control of the output on each 10 foot section of the machine.





Sectional control technology

Seed Hawk sectional control technology is an innovative way to eliminate overlaps and save on input costs. It works in conjunction with onboard GPS to lift openers when previously seeded ground is encountered, and shut down metering of seed and fertilizer, which reduces ground disturbance and doubling up of inputs.

Lifting the openers

When the machine encounters previously seeded ground the toolbar automatically lifts the openers in individual 10 feet sections. This avoids disturbing the precision seed and fertilizer placement already completed. Additionally it prevents plugging in tight turns around potholes, and minimizes bare soil for weed development.



Eliminate overlaps and save on input costs

Sectional Control Technology delivers the precision to reduce seeding costs by 10% or more depending on the width of your toolbar, the variability of your land and moisture conditions.

By reducing overlap on headlands as well as when seeding around water, potholes and brush, you benefit from reduced seed and fertilizer costs.

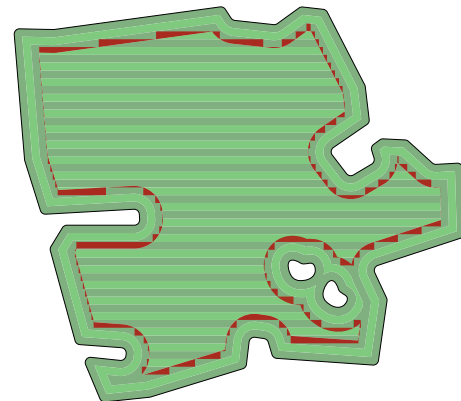

More uniform fields

Eliminating overlap of seed and fertilizer provides uniform plant stands with great yield potential. Lodging risk is minimized due to reduced overlap that causes excess fertilizer application and thicker plant stands than desired.



Variable rate

The amount of fertilizer and seed required to achieve desired yield will vary across the field and, most times, over the width of the toolbar. Seed Hawk's iCon system is compatible with industry leading prescription mapping to dial in the exact amount of product desired, reducing the amount of inputs used. Each 10 feet of toolbar has its own seed and fertilizer meter to ensure greater accuracy in variable terrain.



Blockage monitoring

In order to achieve a uniform plant stand across the field, fertilizer and seed runs must be free of blockage at all times. Seed Hawk's wireless blockage system constantly monitors the flow of each run right on the iPad, eliminating the need for wiring harnesses.

Product flexibility

With four tanks on the Air Carts plus the option to add liquid or NH₃ fertilizer, Seed Hawk seeders are able to adapt to any preference regarding the use of different products in a seeding application. All products are controlled through the iPad-based control system iCon.



Väderstad iCon - wireless control system

The iCon Wireless Control System is a tablet-based control system for simple, complete control of your Seed Hawk air cart and toolbar. You will benefit from user-friendly remote setup and calibration as well as real-time monitoring and control.



Highly productive meets highly intuitive

The iCon Wireless Control System lives on an iPad, making it intuitive and easy to use – just like the machine it controls. It features a simple interface, home screen automation and perating enhancements like the Acres to Empty and in-field calibration features. Acres to Empty tells you instantly how many acres remain until your next product fill. The in-field calibration function confirms static calibration values while seeding, using load cell data. This information is transmitted wirelessly to the iCon Control System to ensure you are applying products at the correct rates throughout the field.

Freedom to move

Wireless control provides big benefits for seed drill systems. Carry your iCon controlled tablet with you to gain full seeder control and eliminate the need to go back and forth between the tractor cab and machine. The portability simplifies calibration and helps to troubleshoot for blockages, fill the tanks to the appropriate level, or even use the meters to empty the air cart. Plus, you get less in-cab wiring and fewer connection points.



Always up to date

At Väderstad, we find it very important to support and service all our customers to the fullest. Therefore, all iCon software updates are easy to download free of charge.

With iCon, you are always sure to benefit from the latest technology and the newest innovative solutions from Väderstad.

Fit-to-Field rate adjustment

The Fit-to-Field function makes product changes much easier. This iCon feature automatically adjusts seed and fertilizer rates to empty* the Seed Hawk air cart over the remaining acres in your field. It's easy and efficient, eliminating the guess work when emptying the cart.

* 200lbs. of product will remain in the bin at empty



Your Data. Your Way

iCon utilizes a cloud based system to download prescription maps and upload completed job reports so you can access them from anywhere.

Excellent agronomic performance

Seeding is the operation that sets conditions for crop performance throughout the year. It is important to not only choose a seeding system that will produce crops of the highest quality and yield but will also perform under all types of weather conditions. Give your crop the best opportunity to succeed while reducing risk at the same time.



Soil health

The Seed Hawk opener minimizes disturbance which can reduce erosion and increase soil organic matter. This results in greater fertilizer use efficiency, improved soil tilth, increased moisture holding capacity and an ideal environment for micro-organisms.

Quick germination

Conditions can change quickly in growing areas all over the world. Quick germination and establishment allows growers to plant at the optimum time for envelopment in their area. Some factors include moisture use, development stage timing and maturity timing. Quick, vigorous emergence also allows crops to withstand early season weather and insect pressure.





Even crop development

An evenly growing and maturing crop throughout the field is essential for crop management during the growing season. Proper herbicide and other pesticide application timing is often based on crop stage. An even crop ensures that all plants are at the correct stage for application or harvest management.

Performance in dry conditions

Moisture is the most common limiting factor when it comes to plant growth and it is important to choose a seeding system that delivers results even when conditions are less than ideal. In dry conditions, if the fertilizer is placed too close to the seed it can result in fertilizer burn. Conversely, if fertilizer is placed too far from the seed, dry conditions can delay root access. Consult with your local agronomist on safe rates of fertilizer in these situations.



Air Cart 660-980

Combining capacity, flexibility and accuracy, Seed Hawk Air Carts will improve productivity on the farm. High capacity fans, large bins and high flotation tires allow you to apply the products you require, even in the toughest conditions.



Innovative technology throughout the Fenix III metering, iCon wireless control system, load cells and intuitive iPad monitor, give the operator real-time data that can be used in the field and recorded for future reference.

When size matters

With its extreme capacity, Seed Hawk Air Carts are designed to give you more time seeding and less time filling. Offered in three sizes the 660, 800 and 980 Air Cart have a total bin capacity of between 660 – 980 bushels. Seed Hawk offers larger tire sizes for better traction and decreased compaction in wet conditions.

Individual bin load cells

Stopping to guess how much product you have left in the tank is a thing of the past. The modular tank design of Seed Hawk Air Carts features individual compartment load cells. The load cells weigh each bin separately and provide real-time verification of remaining product. The iCon Wireless Control software uses the innovative Acres to Empty feature to calculate how many acres it will cover. This ensures more efficient filling times and allows you to pinpoint your required fill volume.



660-980 bu



4



12



18-500 cc

Smart, flexible, efficient



The modular tank design of Seed Hawk Air Carts features individual compartment load cells.



New fill system remote for 800 & 980 Air Carts allows for more functionality including belt speed controls while displaying real-time load cell values for each bin.

Toolbar 45-XL

The Seed Hawk Toolbars provides precise seeding technology, delivering unmatched seed and fertilizer placement in one pass. It is perfect for no-till or minimum tillage operations in all soil conditions.



The Seed Hawk Toolbar comes in two models, the 45 Toolbar or XL Toolbar, with widths ranging from 40' to 84'. Both toolbar styles can be configured for 10" or 12" row spacing.

Big machines that follow the contour

The Toolbars come in 5- or 7-plex frame sections, allowing them to follow the contours of the land. With a contour following range of 18", the independent opener assemblies deliver consistent seed depth, regardless of the terrain. Each opener assembly follows the ground independently by pivoting at the frame, controlled by its

own adjustable hydraulic cylinder. A range of seed and fertilizer knives is available to suit every seeding style.

Wireless blockage monitoring

The wireless blockage system constantly monitors product flow on your Seed Hawk seeding system. If a blockage is detected, it immediately delivers quick, accurate notification of the exact location to your iCon wireless control system. When a blockage location is identified, you can take your tablet out of the tractor cab and carry it with you as you locate the blockage and fix the issue.

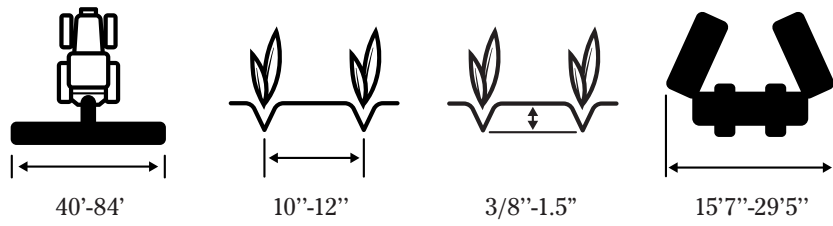

Unparalleled accuracy



Top to bottom overhaul on hydraulic system to improve routing and increase capacity.



New Toolbar Control System (TCS) for pairing with off-brand carts comes with stand alone 5" touch screen.

Air Drill 30

The Seed Hawk 30 is offered in two sizes. The compact combination of air cart and toolbar with low horsepower requirements, makes it a perfect fit for all farming operations.



Seed Hawk 30 is available with a frame width of either 6 m or 8 m. Both machine sizes have a mounted tank with a total volume of 1900L in both the front and rear tanks. The 6 m frame is designed to enable a setup of 24 rows at 250 mm row spacing, or 20 rows at 300 mm row spacing. The larger, 8 m frame is designed for 32 rows at 250 mm row spacing, or 26 rows at 300 mm row spacing.

Narrow transport

The Seed Hawk 30 folds up in a convenient, compact package. Regardless of the configuration, the machine has a transport width of 3 m. The transport height ranges from 3.35 m to 4.06 m, depending on the frame width.

Fenix II metering

Simple, precise metering combined with remote calibration and rollers that can be changed easily to accommodate different seed sizes. The Fenix II metering system uses a fluted roller inside an adjustable barrel for reliable distribution of seed and fertilizer. The durable, anti-static polymer and stainless-steel construction prevents corrosion.

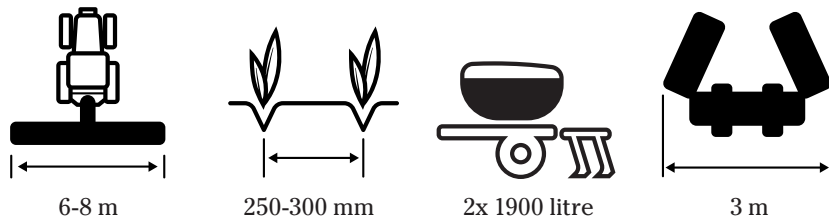

Precision seed placement with just the right fit



For functional storage and delivery regardless of the frame size, the two-bin tank splits seed and fertilizer into two 1900 litre bins.



To enable easy transport Seed Hawk 30 folds to 3 m transport width.

Accessories



Fill system

Growers have the choice between either a 10" fill auger or a conveyor with a 15" belt.



40 bushel bin fill chute

The fill chute folds down and raises the fill point on the 40 bushel bin, up to the same level as the other bins, to make it easier to fill.

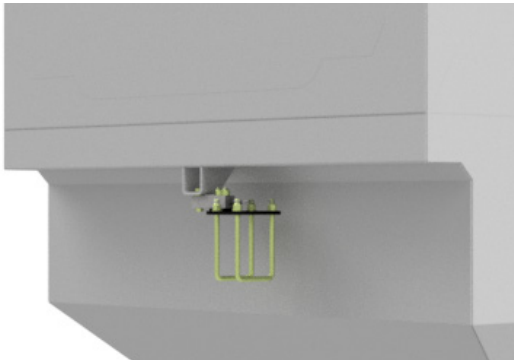

Fill system

Growers have the choice between either a 10" fill auger or a conveyor with a 15" belt.



Stair alarm kit

Sensor kit sounds alarms in the iCon control system when your stairs are left down.



Toolbar tires options

Upgrade to 30.5L32 tires on the rear centre frame for improved floatation in the field and weight carrying during transport.



Cart tires options

On 660 cart upgrade to single IF800 tire or single 1250 from standard 30.5L32. For the 800/980 carts upgrade to dual IF800 tire from standard single 1250.



Bag lift

Allows up to 10 bags of canola to be lifted from the ground to the 40 bu tank, avoiding unnecessary strain of carrying individual bags.

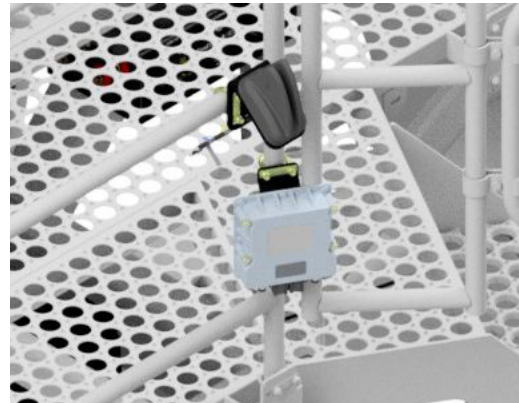

Gateway 260

External antenna for stronger wifi connection that can be wired or wireless.



Devloo mud scrapers

Scrapers are mounted above each packing wheel to continuously clean the packer wheel while opener assembly is engaged in the ground.



iCon Bluetooth Switchbox

Traverse in-field obstacles with ease using the manual switches.

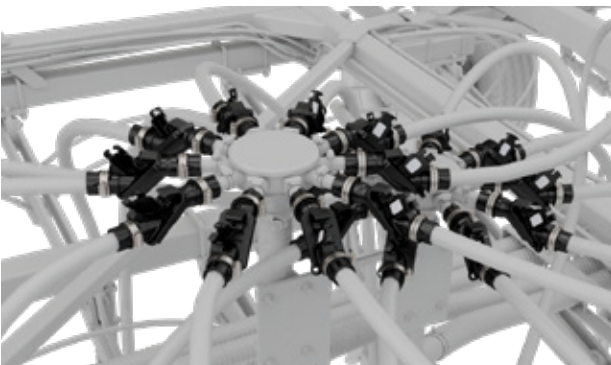

Wireless blockage monitoring

Blockage monitors on each seed tube registers the product passing through. If a blockage would occur you are immediately notified on its location via the wireless iCon control system.

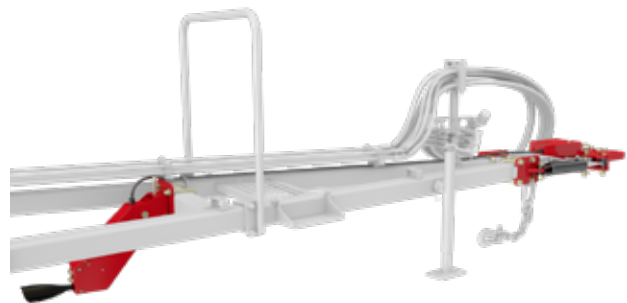

SBR Hitch

Curved paddle sensor detects stubble rows to seed in between. Provides shelter for young seedlings and improves trash flow.

	Air Cart 660	Air Cart 800	Air Cart 980
Metering	Electric	Electric	Electric
Total volume (bu)	660 bu (23,260 l)	800 bu (28,190 l)	980 bu (34,535 l)
Volume Bin 1 (bu)	40 bu (1,410 l)	40 bu (1,410 l)	40 bu (1,410 l)
Volume Bin 2 (bu)	160 bu (5,640 l)	300 bu (10,570 l)	480 bu (16,915 l)
Volume Bin 3 (bu)	160 bu (5,640 l)	300 bu (10,570 l)	300 bu (10,570 l)
Volume Bin 4 (bu)	300 bu (10,570 l)	160 bu (5,640 l)	160 bu (5,640 l)
Dry weight (lbs)*	22,310 (10,120 kg)	32,505 (14,745 kg)	35,000 (15,875 kg)
Loaded weight min/max (lbs)**			
Transport width with standard tires (feet)	20' (6.1 m)	17'4" (5.3 m)	17'4" (5.3 m)
Transport width with optional tires (feet)	15'10" (4.8 m)	20'5" (6.2 m)	20'5" (6.2 m)
Transport length (feet)	36'6" (11.1 m)	44'3" (13.5 m)	50'9" (15.5 m)
Transport length with auger (feet)	36'6" (11.1 m)	44'3" (13.5 m)	50'9" (15.5 m)
Transport length with conveyor (feet)	37'4" (11.4 m)	45'8" (13.9 m)	50'9" (15.5 m)
Transport height (feet)	15'10" (4.8 m)	15'10" (4.8 m)	15'10" (4.8 m)
Ground clearance (inches)	18.5" (470 mm)	18.5" (470 mm)	18.5" (470 mm)
Configuration	TBH or TBT	TBH	TBH
Fan capacity max (rpm)***	4400	4400	4400
Hydraulic requirement (gpm)	56	56	56
Hydraulic circuits required	2 + case drain	2 + case drain	2 + case drain

45 Toolbar

Toolbar size/width	40', 12.2 m	50', 15.2 m	60', 18.3 m
Row spacing (inches)	10/12 (250/300 mm)	10/12 (250/300 mm)	10/12 (250/300 mm)
Number of rows at 254mm (10") spacing	48	60	72
Number of rows at 305mm (12") spacing	40	50	60
Weight (lbs)****	24,895 (11,290 kg)	29,965 (13,590 kg)	32,745 (14,850 kg)
Transport width (feet)	15'7" (4.75 m)	15'5" (4.7 m)	15'5" (4.7 m)
Transport length (feet)*****	35'2" (10.7 m)	35'2" (10.7 m)	35'2" (10.7 m)
Transport height (feet)	16'1" (4.9 m)	16'9" (5.1 m)	16'9" (5.1 m)
Ground clearance (inch)	12" (300 mm)	12" (300 mm)	12" (300 mm)
Frame sections	5-plex	5-plex	5-plex
Recommended working speed (mph)	4.5-5 (7 - 8 km/h)	4.5-5 (7 - 8 km/h)	4.5-5 (7 - 8 km/h)
Hydraulic circuits required	2	2	2

XL Toolbar

Toolbar size/width	70' (21.3 m)	80' (24.4 m)	84' (25.6 m)
Row spacing (mm)	10/12 (250/300 mm)	10/12 (250/300 mm)	12 (300 mm)
Number of rows at 254mm (10") spacing	84	96	N/A
Number of rows at 305mm (12") spacing	70	80	84
Weight (lbs)****	43,365 (19,670 kg)	46,005 (20,865 kg)	47,205 (21,410 kg)
Transport width (feet)	29' (8.84 m)	29' (8.84 m)	29'5" (8.96 m)
Transport length (feet)*****	36'11" (11.25 m)	36'11" (11.25 m)	36'11" (11.25 m)
Transport height (feet)	17'11" (5.5 m)	17'11" (5.5 m)	17'11" (5.5 m)
Ground clearance (inches)	12 (300 mm)	12 (300 mm)	12 (300 mm)
Frame sections	7-plex	7-plex	7-plex
Recommended working speed (km/h)	4.5-5 (7 - 8 km/h)	4.5-5 (7 - 8 km/h)	4.5-5 (7 - 8 km/h)
Hydraulic circuits required	2	2	2

*Assumes dual 30.5L32 tires on Air Cart 660 and dual IF800 tires

**Assumes all bins are full of 60lb/bu material (wheat & blended fertilizer)

***Depends on tractor configuration

****Assumes 12" spacing, front hitch with SBR, single 30.5 rear axle and clevis rear hitch

*****Assumes clevis style hitch. If equipped with SBR hitch, add 34 cm (13.5")

Air Drill 30

Toolbar size/width	6m	8m
Row spacing (mm)	250/300 (10"/12")	250/300 (10"/12")
Number of rows at 254mm (10") spacing	24	32
Number of rows at 305mm (12") spacing	20	26
Working width (m)	6.1 (20')	7.93/8.13 (26'/26'8")
Transport width (m)	3 (9'10")	3 (9'10")
Transport length (m)*	9.86 (32'4")	9.86 (32'4")
Transport height (m)	3.35 (11')	4.06 (13'4")
Ground clearance (mm)	305 (12")	305 (12")
Volume bin 1 (l)	1 900 (55 bu.)	1 900 (55 bu.)
Volume bin 2 (l)	1 900 (55 bu.)	1 900 (55 bu.)
Weight (kg)	4 500 (9 920 lbs.)	5 600 (12 345 lbs.)
Recommended working speed (km/h)	7 - 8 (4.5-5 mph)	7 - 8 (4.5-5 mph)
Hydraulic requirement (gpm)	40	40
Hydraulic circuits required	3 DA & 2 + FR	3 DA & 2 + FR

Väderstad has made every attempt to accurately portray our product lineup. However, due to our commitment to continually innovate our technologies to provide our customers the best possible products, some products may not be manufactured as shown in this brochure. Exact specifications for each product will be confirmed at the time of ordering.

Reliable and durable farm machinery



*Entire machine comes
with 12 month or 25,000
acres warranty from
Warranty Start Date. **

** Warranty valid period is which-
ever limit occurs first.*



*Frame structure comes
with 36 month or 25,000
acres warranty from
Warranty Start Date. **



Where farming starts